

The camera and the eye

The camera

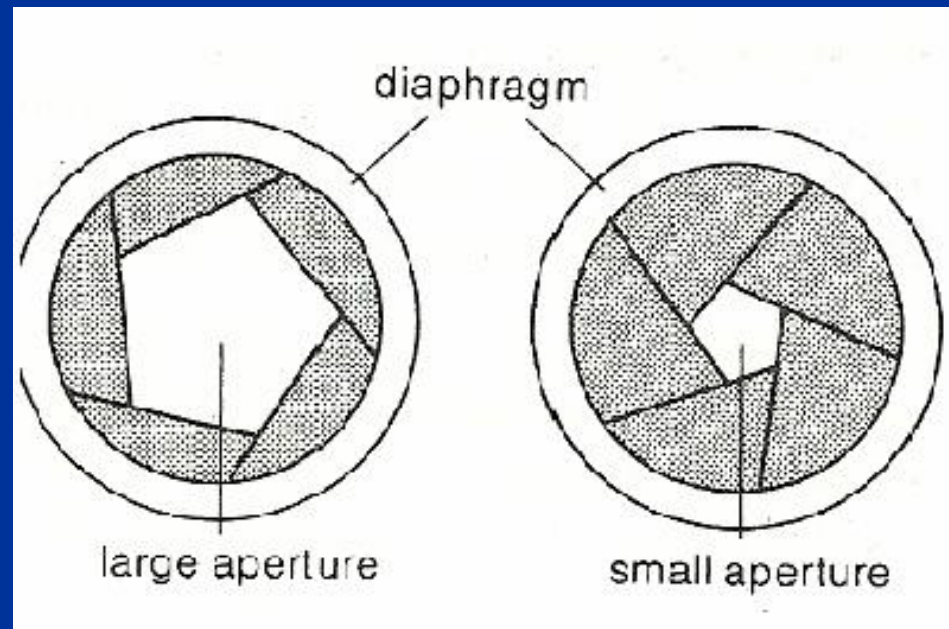

The eye

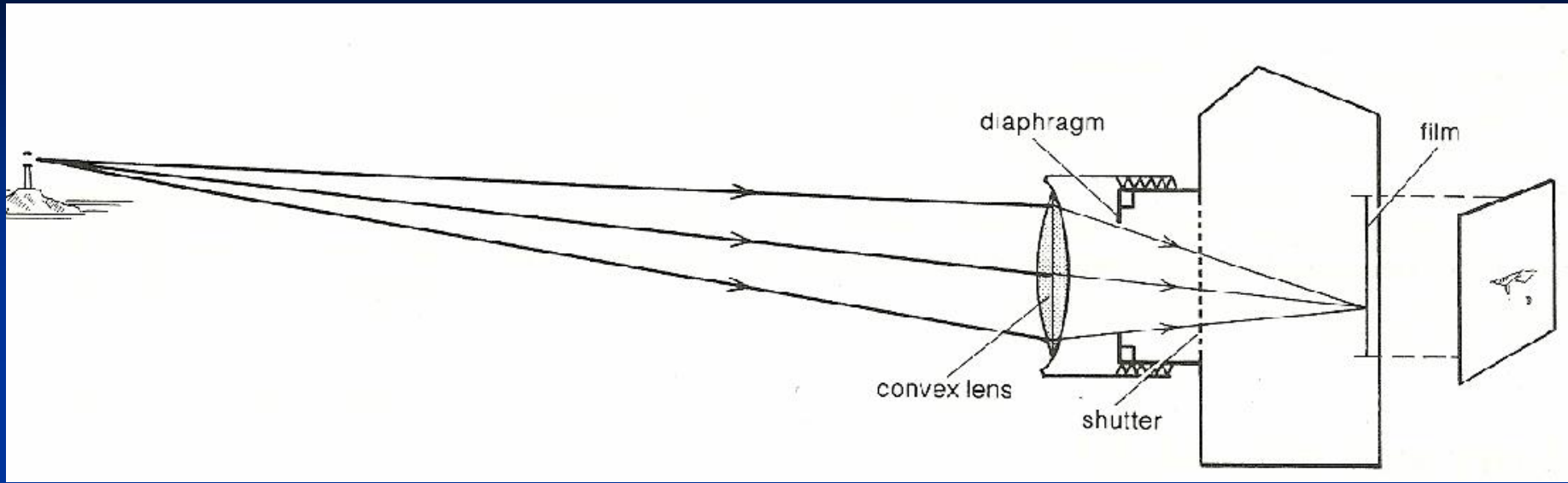
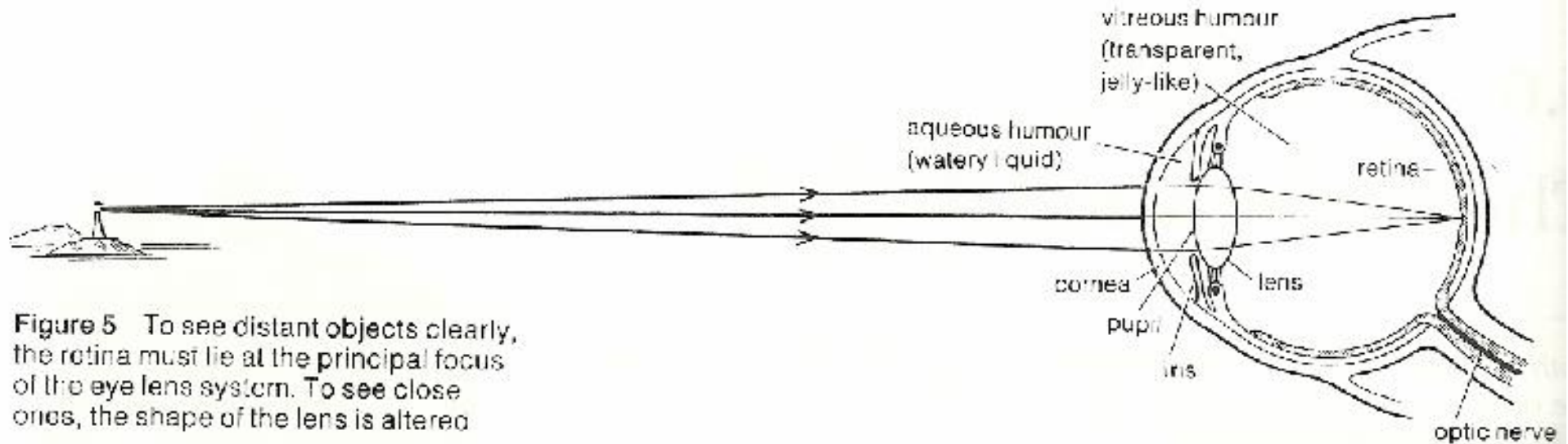

Figure 5 To see distant objects clearly, the retina must lie at the principal focus of the eye lens system. To see close ones, the shape of the lens is altered

Accommodation – light entering the eye is converged mainly by the cornea and the watery liquid behind it. The lens itself is used to make focusing adjustments - a process called accommodation.

Short-sighted people

- Cannot see distant objects clearly
- The eye-ball is too long for the lens system and rays from any distant object come to a focus just in front of the retina.
- A concave lens is placed in front of the eye to correct the fault.

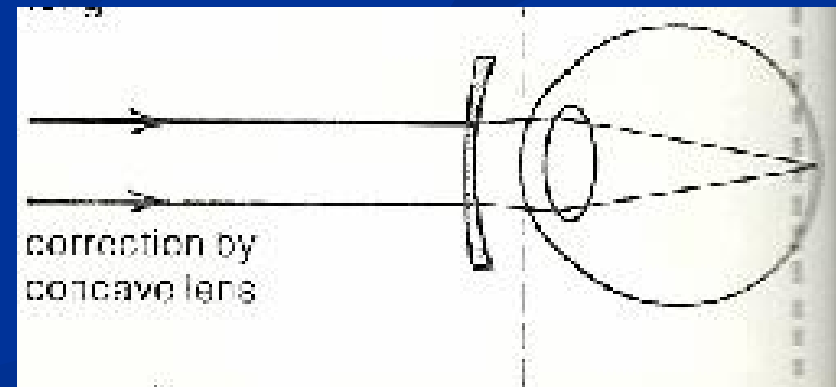
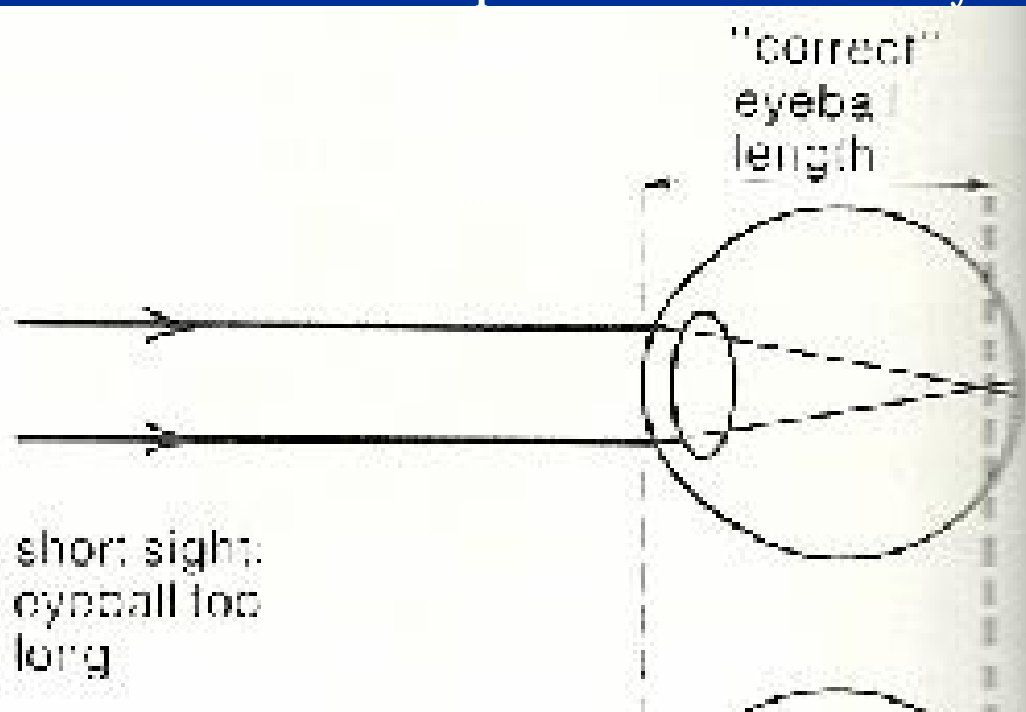
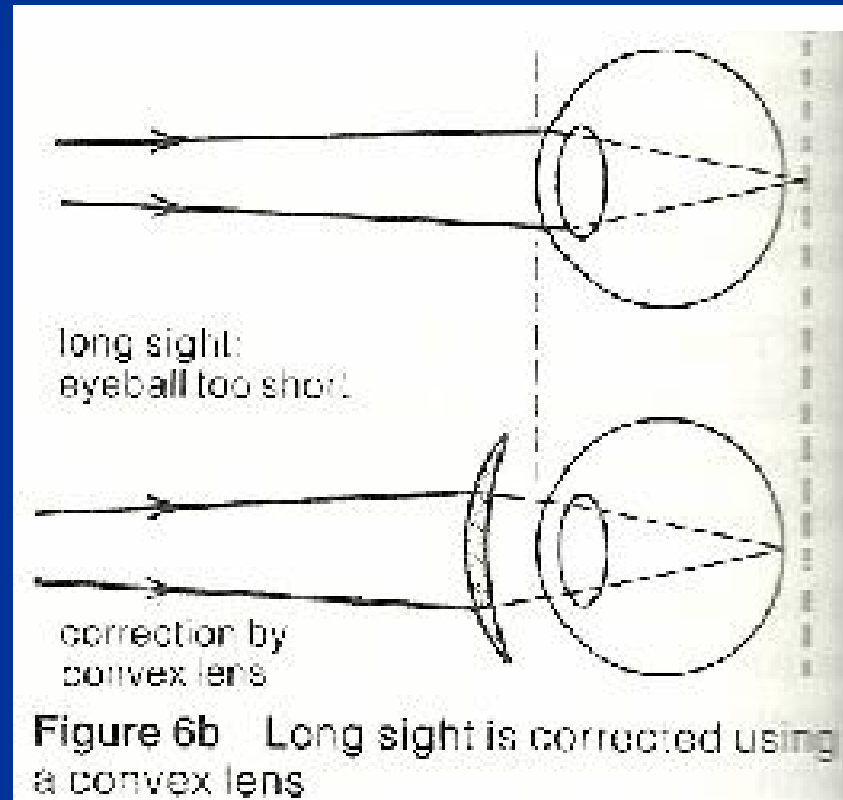

Figure 6a Short sight is corrected using a concave lens

Long-sighted people

- Cannot see close objects clearly
- The eye-ball is too short for the lens system and rays from a close object converge towards a point just beyond the retina.
- A convex lens is placed in front of the eye to correct the fault.



Power of lens

$$\Phi = 1 / f = 1/d - 1/ a$$

d – conventional distance (25 cm)

a – distance of the object from the lens (m)

Φ – power of lens (dioptry, D)

f – focal length of the lens (m)

Short-sighted people – concave lens – Φ = negative values of D

Long-sighted people – convex lens – Φ = positive values of D

•What is the power of glasses for short-sighted eye with a close point of 10cm.

•What about power of glasses for long-sighted eye with a close point of 50cm.

Viewing angle

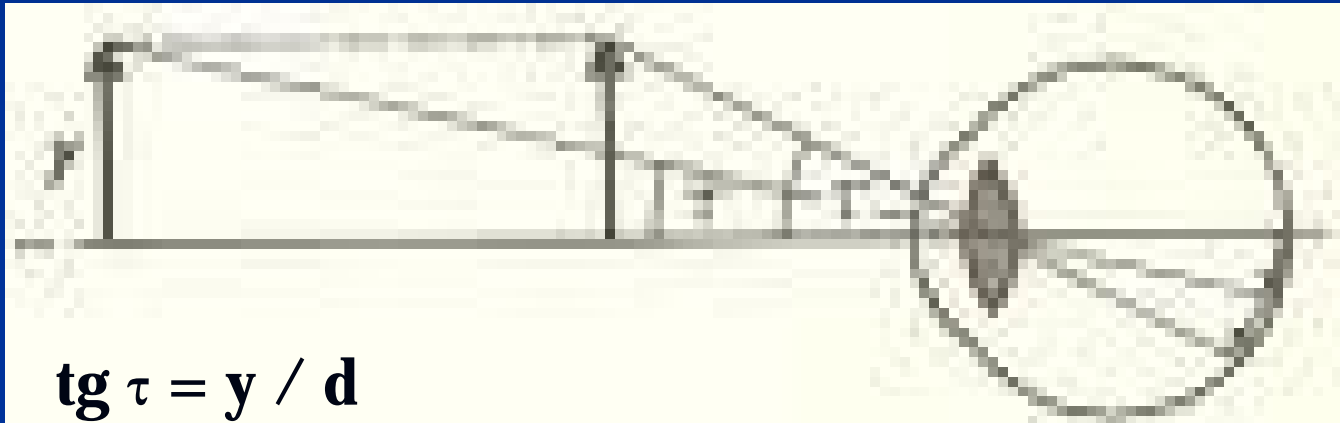

y – length of an object

d – conventional distance (25cm)

Two objects can be seen as two different points only in the case that the viewing angle is greater or equal to $1'$!

Magnifying glass

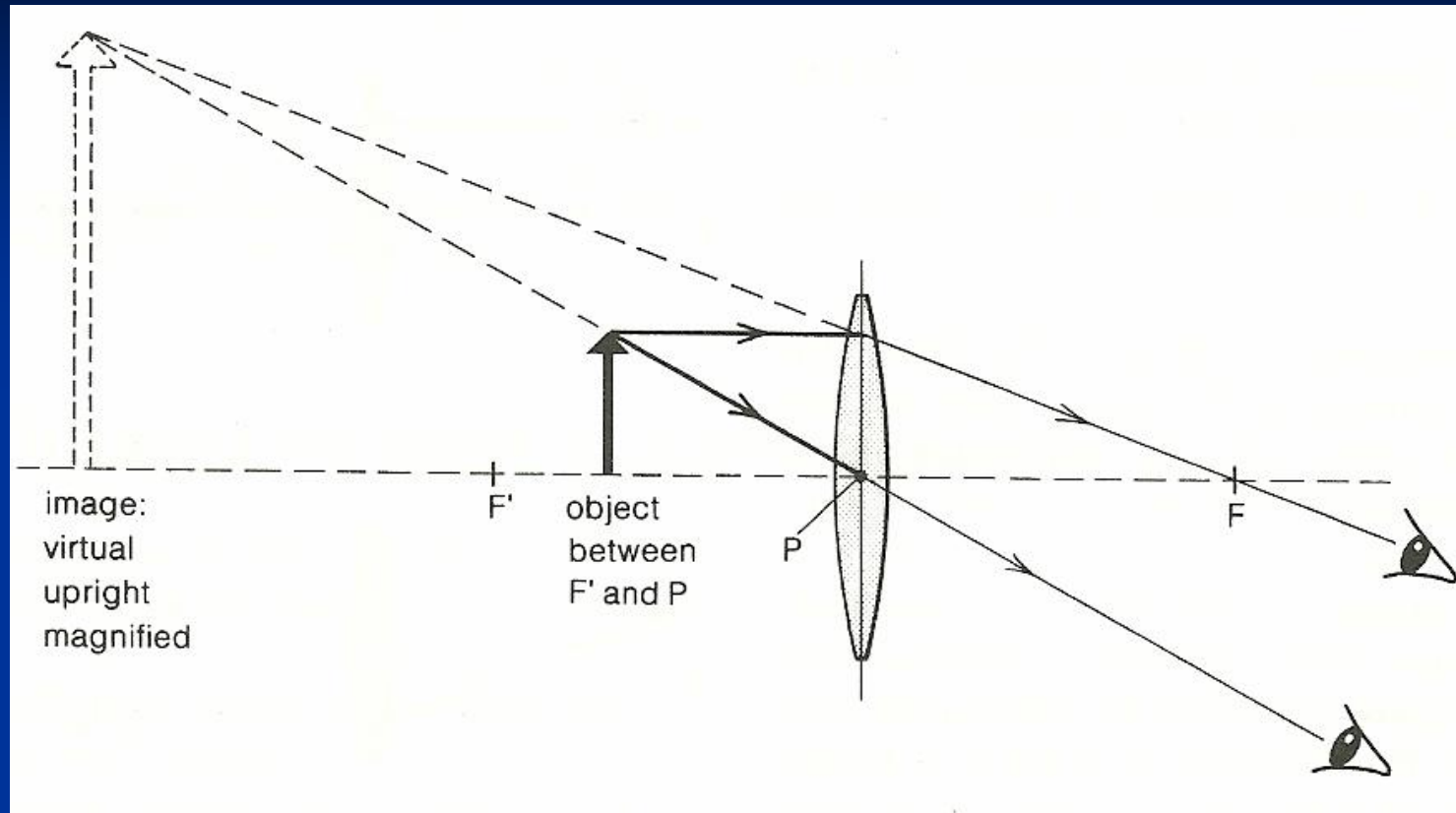

Angular magnification: $\gamma = d / a$

a – distance of the object from the lens

d – conventional distance (25 cm)

The microscope

Angular magnification of microscope:

$$\gamma = \Delta d / (f_1 f_2)$$

Δ – optical interval – distance between the f_1 and f_2 (m)

d – conventional length (25cm)

f_1 – focal length of the eyepiece (m)

f_2 - focal length of the objective (m)

• Calculate distance between the f_1 and f_2 of the microscope and length of its tube, if $f_1=5\text{mm}$ and $f_2=2.5\text{cm}$. The angular magnification of the microscope is $\gamma=320$.